

**Product: MEETING TABLE**

Rectangular classic meeting table in wood, glass or leather coating. It is equipped with wiring system and top access. It is also available in several dimensions and combinations of fine finishes. "Portale" legs are 50 mm thick, while tops are 30 mm thick.



**TECHNICAL FEATURES**

**Top:**

**Veneer:** the tops are made of wood particles, wood veneer or leather coated.

**Soft Leather.**

**Back-lacquered etched glass.**

**Gambe:**

**Veneer:** the legs are made of wood particles, wood veneer coated. Also available in sablè lacquered finish.

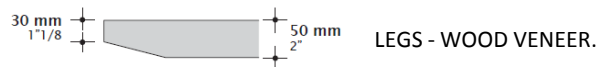

With sablè lacquered legs the veneer top is not available.

**FINISHES**

**Top:**

**Veneer:** Magnolia, Nuvola stained Oak, Natural Oak 2016, American Walnut, Eucalyptus, Wengè, Zebrano Brown, Ebano.

**Back-lacquered etched glass:** White, Silver, Titanio, Brown, Alfa Red.

**Soft Leather.**

**Legs:**

**Sablè lacquered:** UE White, Titanio.

**Veneer:** see desk veneers.

**DIMENSIONS**

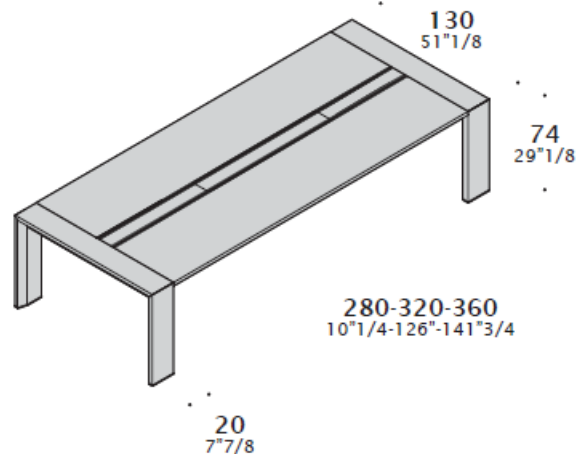

**ELECTRIFICATION**

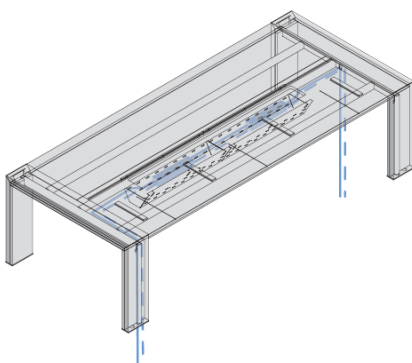

**Options:**

H74 + L280 + D130

H74 + L320 + D130

H74 + L360 + D130