

Product: MEETING TABLE

Frame Mini Meeting allows to create a flexible office environment, facilitating the communication between people. It is suitable for sharing workstations (desk sharing, booking system, meeting desk).

Frame Mini Meeting consists of a small meeting table and a technical column for video screen housing.

It is the ideal solution for focus group, brief presentation or stand-up meeting.



TECHNICAL FEATURES

Top: top is made in clear glass or back-lacquered etched glass 15 mm thick.

Column: structure made of wood particles in Sablè lacquered finish.

Legs: base in tubular metal structure, in powder coated metal or Luxury metal.

FINISHES

Top:
Clear glass.

Back-lacquered etched glass: White, Silver, Titanio, Brown, Alfa Red.

Frame:
Sablè lacquered, available in different sample collection colours.

Legs:
Powder coated metal: glossy or matt White Snow, glossy UE White, glossy Silver, matt Titanio, matt Green Black, matt Brown, matt Carbon Glacè, glossy Alfa Red.

Luxury metal: Chromed, glossy Nickel Black, matt Bronze, matt Brass, matt Antique Brass, Pewter Quarz, Brunished Cobalt.

ACCESSORIES



Monitor bracket.

ELECTRIFICATION

TYPE 6

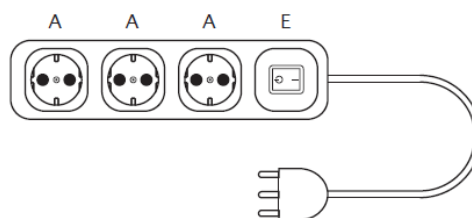
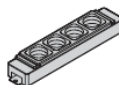

TYPE 7

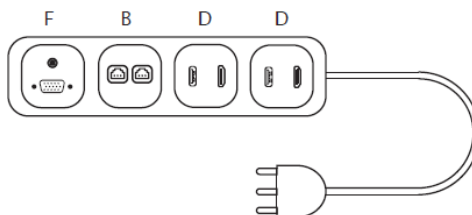
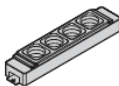

- A - Schuko - UE socket
- B - n°2 RJ45 socket cat. 6 (data/telephone)
- D - n°1 HDMI socket (video) + n°1 USB socket
- E - n°1 light switch
- F - n°1 VGA

- On request we can also supply international sockets

Multiple sockets are provided with 3m lenght cable and Schuko plug

DIMENSIONS

Meeting table H45

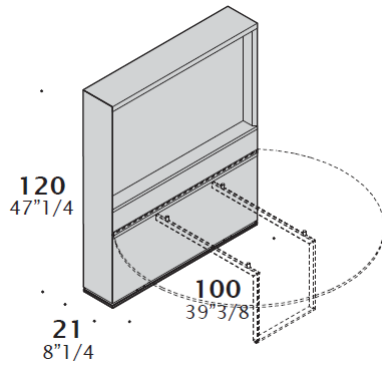
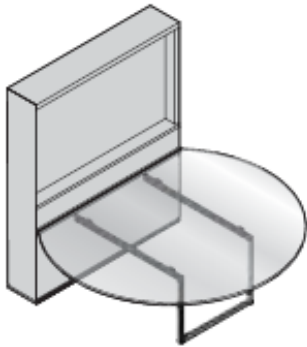

Column.

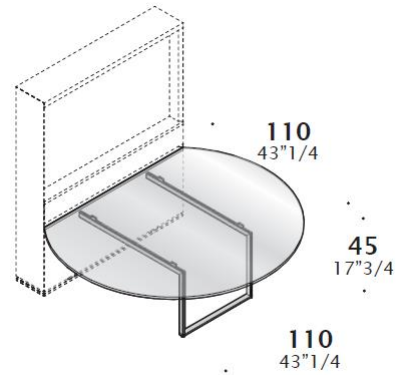

Top.

