

TOBIAS *Design: Frighetto Workshop*

ARTICLE: SOFA

An ample and particular flared seat is the distinctive mark of the Tobias sofa. A family of modular seats with outstanding personality and tremendous comfort. The collection offers numerous size variations with coordinated armchairs and pouf in various sizes.

TECHNICAL CHARACTERISTICS

The load-bearing structure, on which the spring system (consisting of metal frames and elastic webbing) rests is made of multilayer beech and poplar wood. The padding is made of expanded density-differentiated polyurethane.

The seat and back cushions are made of highest quality down feathers that have been sterilized, sanitized and treated to be hypoallergenic, and contain an insert of density-differentiated polyurethane. The backrest cushions are made of the highest quality down feathers, which are recommended for the greatest comfort. Suggested 2 cushions for elements.



DIMENSIONS

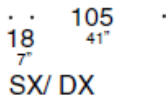
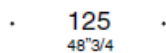

Terminal



SX/ DX

Terminal

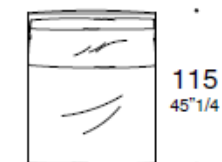
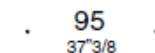

Linear

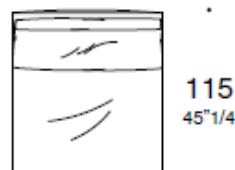

Linear

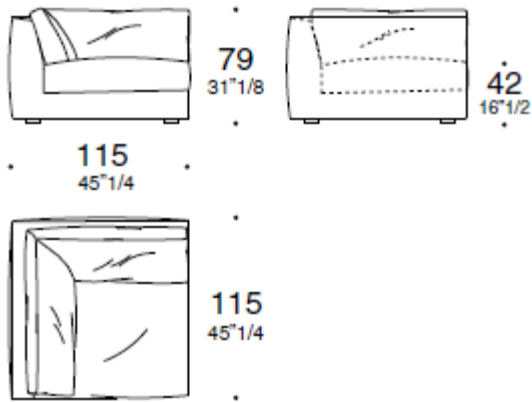

Corner



Cushions

FINISHES

Fabrics Cat. F,G,H,L,M, Ecoleather, Leather, Extra Leather, Super Leather

ARTICLE: ARMCHAIR

An ample and particular flared seat is the distinctive mark of the Tobias sofa. A family of modular seats with outstanding personality and tremendous comfort. The collection offers numerous size variations with coordinated armchairs and pouf in various sizes.

TECHNICAL CHARACTERISTICS

The load-bearing structure, on which the spring system (consisting of metal frames and elastic webbing) rests is made of multilayer beech and poplar wood. The padding is made of expanded density-differentiated polyurethane.

The seat and back cushions are made of highest quality down feathers that have been sterilized, sanitized and treated to be hypoallergenic, and contain an insert of density-differentiated polyurethane. The backrest cushions are made of the highest quality down feathers, which are recommended for the greatest comfort. Suggested 2 cushions for elements.



DIMENSIONS

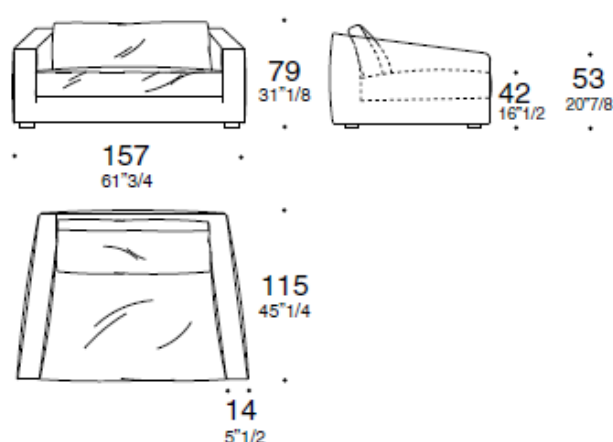
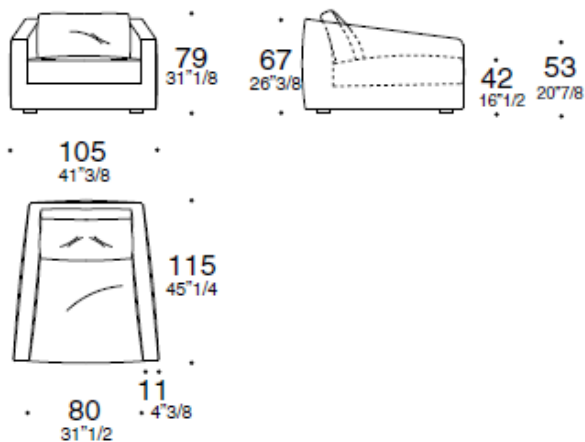

FINISHES

Fabrics Cat. F,G,H,L,M, Ecoleather, Leather, Extra Leather, Super Leather

ARTICLE: POUF

An ample and particular flared seat is the distinctive mark of the Tobias sofa. A family of modular seats with outstanding personality and tremendous comfort. The collection offers numerous size variations with coordinated armchairs and pouf in various sizes.

TECHNICAL CHARACTERISTICS

The load-bearing structure, on which the spring system (consisting of metal frames and elastic webbing) rests is made of multilayer beech and poplar wood. The padding is made of expanded density-differentiated polyurethane.

The seat and back cushions are made of highest quality down feathers that have been sterilized, sanitized and treated to be hypoallergenic, and contain an insert of density-differentiated polyurethane. The backrest cushions are made of the highest quality down feathers, which are recommended for the greatest comfort. Suggested 2 cushions for elements.



DIMENSIONS

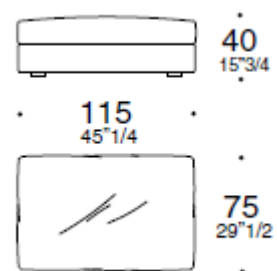
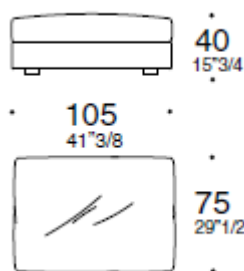
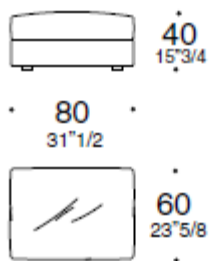

FINISHES

Fabrics Cat. F,G,H,L,M, Ecoleather, Leather, Extra Leather, Super Leather