

Jump

Design by OIL Design Lab

Jump è una linea di pouf composta da 3 forme curvilinee indipendenti che si combinano tra di loro. Un elemento rimovibile funge, nella dimensione più grande, da piccolo schienale.



DESCRIZIONE TECNICA



Struttura

La struttura interna è in massello di abete e multistrato di pioppo e sostiene il molleggio a fasce elastiche.

Imbottitura

L'imbottitura è in poliuretano espanso a densità differenziate.

Rivestimento

Rivestimento in Tessuto One.

DIMENSIONI

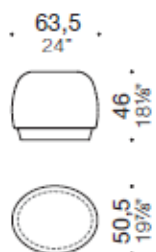

Jump, pouf ovale medio

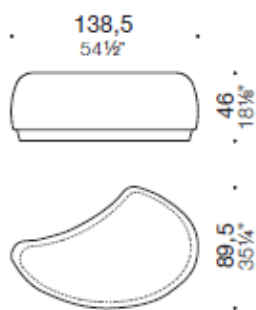

Jump, pouf virgola

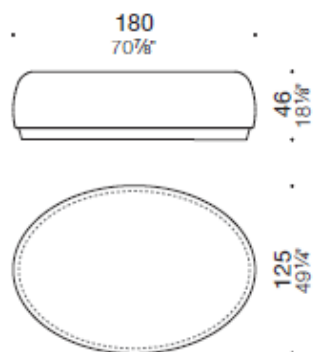

Jump, pouf ovale

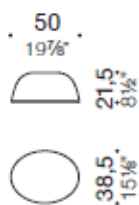

Jump, schienale pouf



Composizione pouf Jump.





HEADQUARTER

Estel Group srl
Via Santa Rosa 70
36016 Thiene (VI) – Italy
Tel. +39 0445 389611
Fax +39 0445 808801
www.estel.com

Le informazioni riportate si basano
sugli ultimi listini pubblicati.
L'Azienda si riserva il diritto di
apportare modifiche ai prodotti senza
preavviso.

ESTEL rev. 01_06/2020
