

Jump

Design by OIL Design Lab

Jump is a line of poufs made up of 3 independent curved shapes that can be combined with each other. In the larger size, the removable element can also serve as a small backrest.



TECHNICAL FEATURES



Structure

Inner structure in solid fir wood and poplar plywood with elastic bands support.

Padding

Padding in polyurethane in different grades of density.

Upholstery

One fabric.

DIMENSIONS

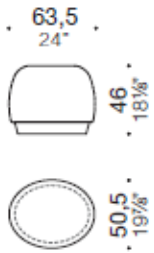

Jump, elliptical medium pouf

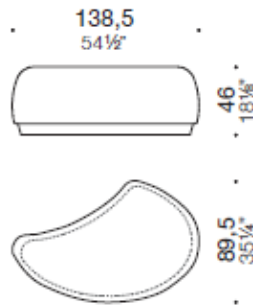

Jump, comma shaped pouf

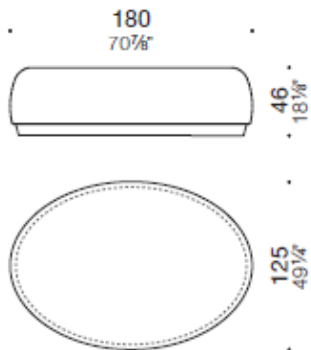

Jump, elliptical big pouf

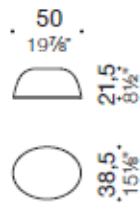

Jump, backrest pouf





HEADQUARTER

Estel Group srl
Via Santa Rosa 70
36016 Thiene (VI) – Italy
Tel. +39 0445 389611
Fax +39 0445 808801
www.estel.com

The information shown is based on the latest published pricelists. Estel reserves the right to make any necessary changes to the products shown at any time without notice.

ESTEL rev. 01_06/2020
